



SMARTEH
LIVING SYSTEMS

USER MANUAL

— Lon Tester
LLT-1

Written by SMARTEH d.o.o.
Copyright © 2007-2009, SMARTEH d.o.o.

User Manual

Document Filename: LLT1_UsrMan
Document Version: 001
June 1, 2009



STANDARDS AND PROVISIONS: Standards, recommendations, regulations and provisions of the country in which the devices will operate, must be considered while planning and setting up electrical devices. Work on 230 VAC network is allowed for authorized personnel only.

DANGER WARNINGS: Devices or modules must be protected from moisture, dirt and damage during transport, storing and operation.

WARRANTY CONDITIONS: For all modules LONGO Motor Drive - if no modifications are performed upon and are correctly connected by authorized personnel - in consideration of maximum allowed connecting power, we offer warranty for 24 months from date of sale to end buyer. In case of claims within warranty time, which are based on material malfunctions the producer offers free replacement. The method of return of malfunctioned module, together with description, can be arranged with our authorized representative. Warranty does not include damage due to transport or because of unconsidered corresponding regulations of the country, where the module is installed.



This device must be connected properly by the provided connection scheme in this manual. Misconnections may result in device damage, fire or personal injury.



Hazardous voltage in the device can cause electric shock and may result in personal injury or death.



NEVER SERVICE THIS PRODUCT YOURSELF!

This device must not be installed in the systems critical for life (e.g. medical devices, aircrafts, etc.).



If the device is used in a manner not specified by the manufacturer, the degree of protection provided by the equipment may be impaired.

Waste electrical and electronic equipment (WEEE) must be collected separately!

LONGO Motor Drive complies to the following standards:

- EMC:EN 61000-6-2 (EN 50082), EN 61000-6-4 (EN 50081)
- LVD: IEC 61010
- Vibrations and climatic-mechanical: EN 60068-2-6, EN 60068-2-27, EN 60068-2-29

MANUFACTURER:

SMARTEH d.o.o.
Trg tigrovcev 1
5220 Tolmin
Slovenia



Index

Lon Tester LLT-1

1 DESCRIPTION.....1

2 GETTING STARTED WITH LLT-1 TESTER.....2

 2.1 Installing batteries.....2

 2.2 Switch on/off.....3

3 NETWORK TESTING4

 3.1 Testing line shorted using LLT-1 Master tester.....4

 3.2 Testing signal level.....5

 3.3 Testing transmit/receive operation.....6

 3.4 Where to connect LLT-1 Master and Slave tester.....8

 3.5 Detail description of testing transmit/receive operation.....8

4 NOTES.....9



1 DESCRIPTION

LLT-1 tester is used for quick checking of all kind of LON FT-10 78kbps based network topologies (bus, loop, star,...), primarily built with CAT5+ cabling. The device is made to be simple to use, without previous extended knowledge of Lon works technology. For proper operation (when testing network traffic), testers must work in pairs, like transmitter-master and receiver-slave. When only cable line shorted is being checked, then the transmitter-master device is enough.

LLT-1 tester can check cabling when network is not in operation (no traffic on network) and can also test cabling when network is busy (traffic on network).

There are four important types of information diagnosed by the device:

- Line shorted
- Signal level
- Test OK
- Test FAULT

LLT-1 tester can also be used like “line simulator”. With the internal DIP switches 200m of CAT5+ line can be simulated.



Symbolic picture of LLT-1 tester (Master and Slave Unit)



2 GETTING STARTED WITH LLT-1 TESTER

2.1 Installing batteries

LLT-1 tester is powered from internal batteries (AA type) or external power adapter (both included together with LLT-1 tester). On back side of LLT-1 tester you can find information, how to install batteries correctly (see picture below).

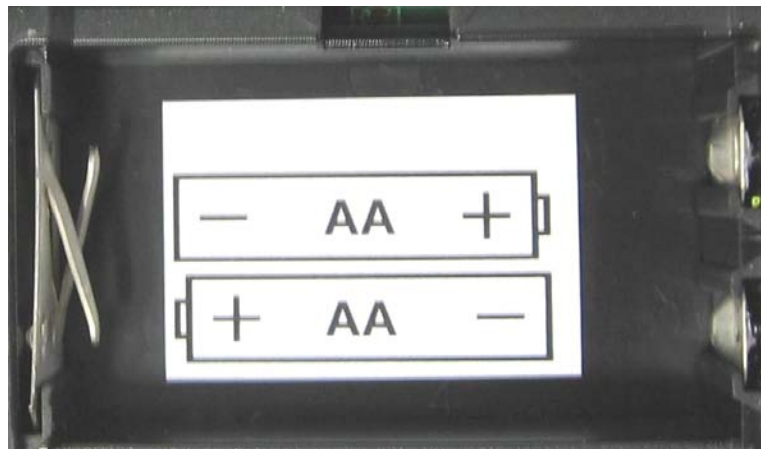

Label on back side of LLT-1 tester

IMPORTANT: When using internal batteries, take care that they are installed correctly. In case of wrong orientation, LLT-1 tester can be damaged.

NOTE: If you have problems switching On LLT-1 tester while operating with batteries, check if they are correctly installed and charged.

WARNING: Using external power adapter will not charge the internal batteries if they are installed. You have to charge batteries before use with the appropriate charger (for example: GP Power Bank Quick 2)



2.2 Switch on/off

If you want to switch on LLT-1 tester, you have to press and hold *Power* button (see picture below) for approx. 1 sec., until power LED is ON. Then you can release the button and power LED must be on. All other LED's will also blink at the same time. Now LLT-1 tester is switched on and it is ready for operation.

If you want to switch off LLT-1 tester, you have to press and hold *Power* button (approx. 3 sec.) until power LED is off. All other LED's will also turn off.



Power button

NOTE: Switch On/Off sequence is same for Master and Slave LLT-1 tester.



3 NETWORK TESTING

LLT-1 tester allows the following tests on the LON network: line shorted, signal level and transmit/receive operation.

3.1 Testing line shorted using LLT-1 Master tester

After power up, LLT-1 tester will start automatically and check continuously if the line is shorted. If so, red LED will light up. (see picture below).



Line shorted

NOTE:

Before testing, connect pair of tested line to any A and/or B terminal on LLT-1 tester.

LLT-1 tester detects CAT5+ line A and B as not shorted, if resistance between line A and line B on LON network is higher than 600ohm. Make sure that all LON nodes are AC coupled to the tested network.

Even if LLT-1 tester shows line shorted, transmit/receive operation may be OK. In this case check also signal level (see chapter 3.2). If signal level is ok (LED not lit), it means that network is working on the limit and further investigation is needed.

During this test LLT-1 Slave Unit can be attached to tested LON network too.



IMPORTANT: Test is valid only, if there is no DC power supply on tested network (for example: if LON nodes are also powered through the network).

3.2 Testing signal level

IMPORTANT: To perform this test both Master and Slave LLT-1 tester must be attached to the tested LON network and power must be switched ON (on both units).
Instruments (Master and Slave) must be connected on both sides of tested line pair of the network under test.

When transmit/receive test is in progress (see chapter 3.3 below) the signal level is measuring and reporting the status. If signal level is under limit (normal limit is 400mVpp), red LED will be ON (see picture below).



Signal level



3.3 Testing transmit/receive operation

IMPORTANT: To perform this test both Master and Slave LLT-1 testers must be attached to the tested LON network and power must be switched ON (on both units).
 Instruments (Master and Slave) must be connected on both sides of tested line pair of the LON network under test.

There are two modes of operation in testing transmit/receive operation. In single mode the test packet sequence is sent once, while in the continuous mode packets of test sequences are sent periodically.

Single mode test:

Push test button once (see picture below) to start single testing mode => blue LED will light up for approx. 3 sec. After this time, the result of the test will be shown. Green LED (Test OK) or red LED (Test FAULT) will light up until the next test is started (push test button once again).



In single mode of testing press “TEST” button once and LLT-1 tester will show the result as “TEST OK” or “TEST FAULT”



Continuous mode test:

Press and hold test button for approx. 3 sec, until blue LED starts to blink. After each blink, test result will be shown. Green LED (Test OK) or red LED (Test FAULT). After each error appears, the red LED (test FAULT) adds another blink comparing to previous blinking.



In continuous mode of testing press “TEST” button for approx. 3 sec. and LLT-1 tester will show the result as “TEST OK” or “TEST FAULT”

Example:

1. If 1 error appears during test, the same indication will be shown on red LED (Test FAULT LED will blink once).
2. If 3 errors appear during test, the same indication will be shown on red LED (Test FAULT LED will blink three times).
3. If more than 7 errors appear during test, Test FAULT LED will be lit continuously.

Starting with next **single** or **continuous** test will clear current test status of green LED (Test OK) or red LED (Test FAULT).



3.4 Where to connect LLT-1 Master and Slave tester

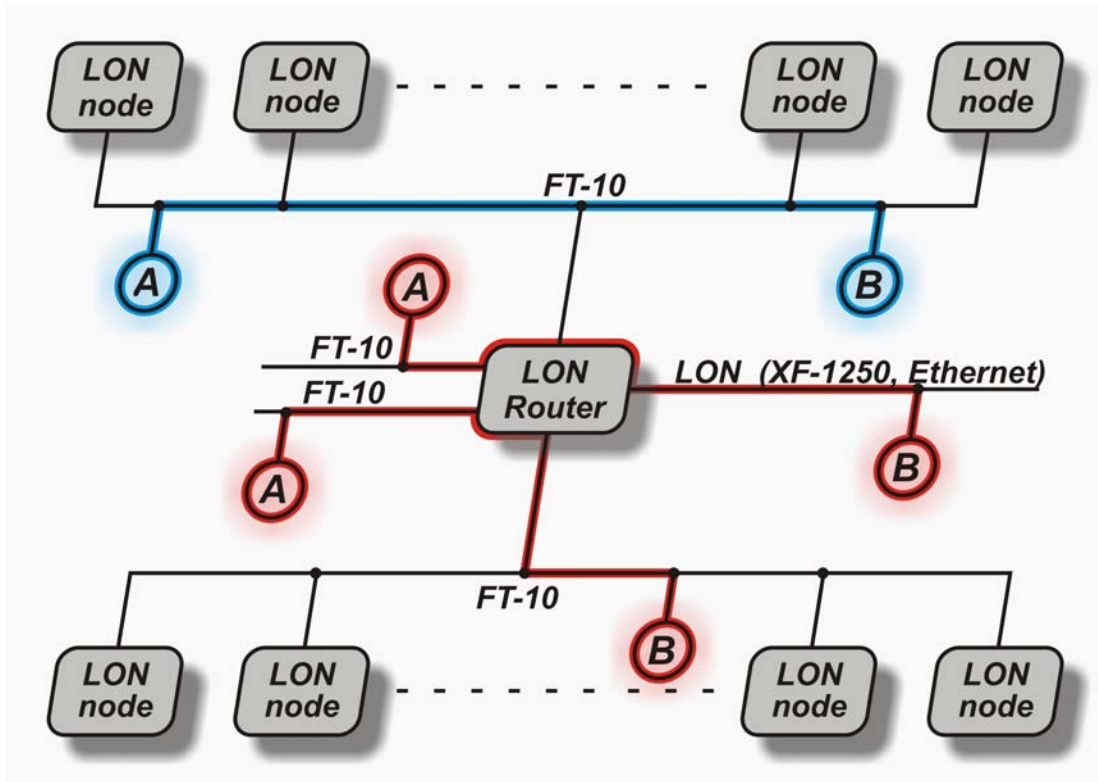

Blue marks show valid connection of LLT-1 Master (A) and Slave (B) testers while red marks show incorrect one.

General rule is that only one Master and Slave pair of LLT-1 testers must be used on one FT-10 channel. Testing through routers, repeaters, gateways,... or to same/different type of channels (like XF-1250) is not supported.

3.5 Detail description of testing transmit/receive operation

WHEN TESTING TRANSMIT/RECEIVE OPERATION, FROM LLT-1 MASTER TESTER NETWORK OUTPUT VARIABLES ARE SENT. THOSE VARIABLES ARE RE-SENT FROM OTHER (LLT-1 SLAVE) TESTER BACK TO LLT-1 MASTER TESTER, WHICH NOW ACTS LIKE THE RECEIVER:

-IF ALL RECEIVED VALUES ARE THE SAME, THEN GREEN LED (TEST OK) STARTS TO LIGHT UP.
-IF ONLY ONE VALUE IS NOT THE SAME, THEN RED LED (TEST FAULT) STARTS TO BLINK (AFTER EACH ERROR APPEARED, THE LED WILL BLINK ONE MORE TIME COMPARING PREVIOUS BLINKING. IF MORE THAN 7 ERRORS APPEARS, LED WILL BLINK CONTINUOUSLY.)

NOTE:

There is no retransmission, if an error appears. That means that the test variables are sent only once. After transmit, LLT-1 tester will wait in receiving mode for 3 sec. After this time, the tester will report the result of the test (OK or FAULT).



4 NOTES

