



SMARTEH
LIVING SYSTEMS

USER MANUAL



Longo Motor Drive
LMD-2

Written by SMARTEH d.o.o.
Copyright © 2007-2010, SMARTEH d.o.o.

User Manual

Document Filename: 208LMD10001002_LMD2_UsrMan
Document Version: 001
September 1, 2010



STANDARDS AND PROVISIONS: Standards, recommendations, regulations and provisions of the country in which the devices will operate, must be considered while planning and setting up electrical devices. Work on 230 VAC network is allowed for authorized personnel only.

DANGER WARNINGS: Devices or modules must be protected from moisture, dirt and damage during transport, storing and operation.

WARRANTY CONDITIONS: For all modules LONGO Motor Drive - if no modifications are performed upon and are correctly connected by authorized personnel - in consideration of maximum allowed connecting power, we offer warranty for 24 months from date of sale to end buyer. In case of claims within warranty time, which are based on material malfunctions the producer offers free replacement. The method of return of malfunctioned module, together with description, can be arranged with our authorized representative. Warranty does not include damage due to transport or because of unconsidered corresponding regulations of the country, where the module is installed.



This device must be connected properly by the provided connection scheme in this manual. Misconnections may result in device damage, fire or personal injury.



Hazardous voltage in the device can cause electric shock and may result in personal injury or death.



NEVER SERVICE THIS PRODUCT YOURSELF!

This device must not be installed in the systems critical for life (e.g. medical devices, aircrafts, etc.).



If the device is used in a manner not specified by the manufacturer, the degree of protection provided by the equipment may be impaired.

Waste electrical and electronic equipment (WEEE) must be collected separately!

LONGO Motor Drive complies to the following standards:

- EMC:EN 61000-6-2 (EN 50082), EN 61000-6-4 (EN 50081)
- LVD: IEC 61010
- Vibrations and climatic-mechanical: EN 60068-2-6, EN 60068-2-27, EN 60068-2-29

MANUFACTURER:

SMARTEH d.o.o.
Trg tigrovcev 1
5220 Tolmin
Slovenia



Index

Longo Motor Drive LMD-2

1 DESCRIPTION.....1

2 FEATURES.....2

3 INSTALLATION.....3

 3.1 Connection scheme.....3

 3.2 Mounting instructions.....5

 3.3 Module labeling.....7

4 TECHNICAL SPECIFICATIONS.....8

5 CHANGES9

6 NOTES.....10



1 DESCRIPTION

LMD-2 is step less motor driver which controls the voltage for the motor in a way that motor does not cause any additional noise for the sake of the driving mode. Main usage of this unit is in air preparation apparatus, where variable fan speed is needed and additional noise would be disturbing.

Output voltage is PWM modulated with frequency higher than 20 kHz. Output is related to control input signal voltage, current, external potentiometer resistance or internal potentiometer position.

Unit can drive also other type of electric equipment which may be controlled with varying the voltage size.



2 FEATURES

Figure 1: LMD2 module

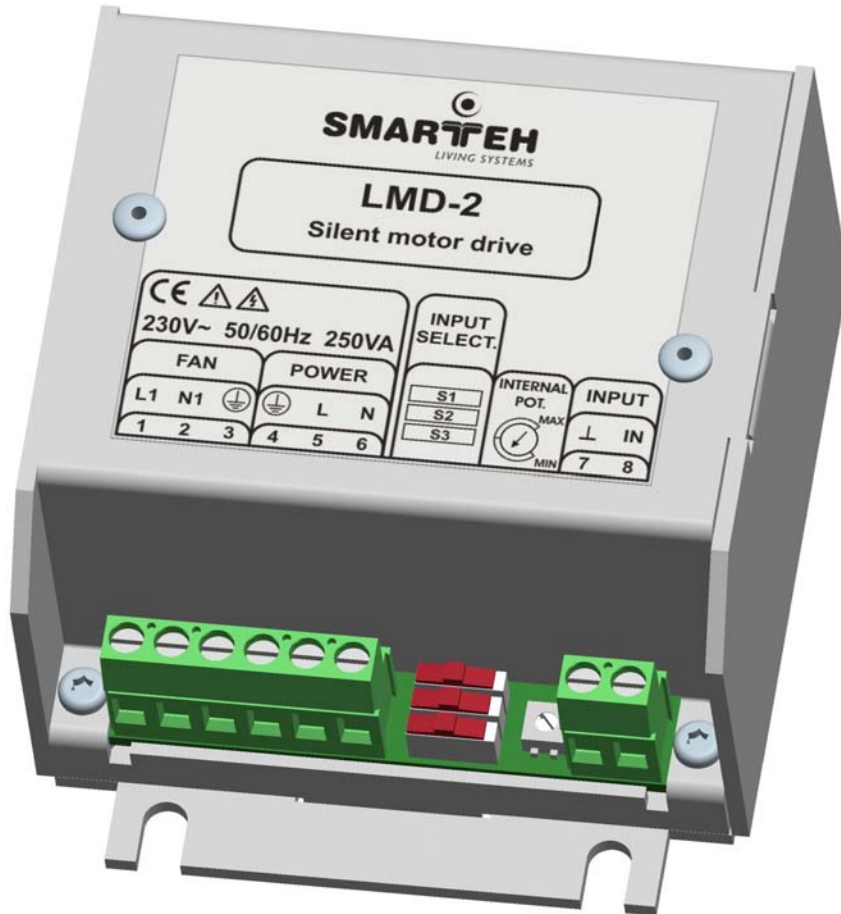

Table 1: Technical data

variable voltage output

load up to 250 VA

various input control signals



3 INSTALLATION

3.1 Connection scheme

Figure 2: Connection scheme

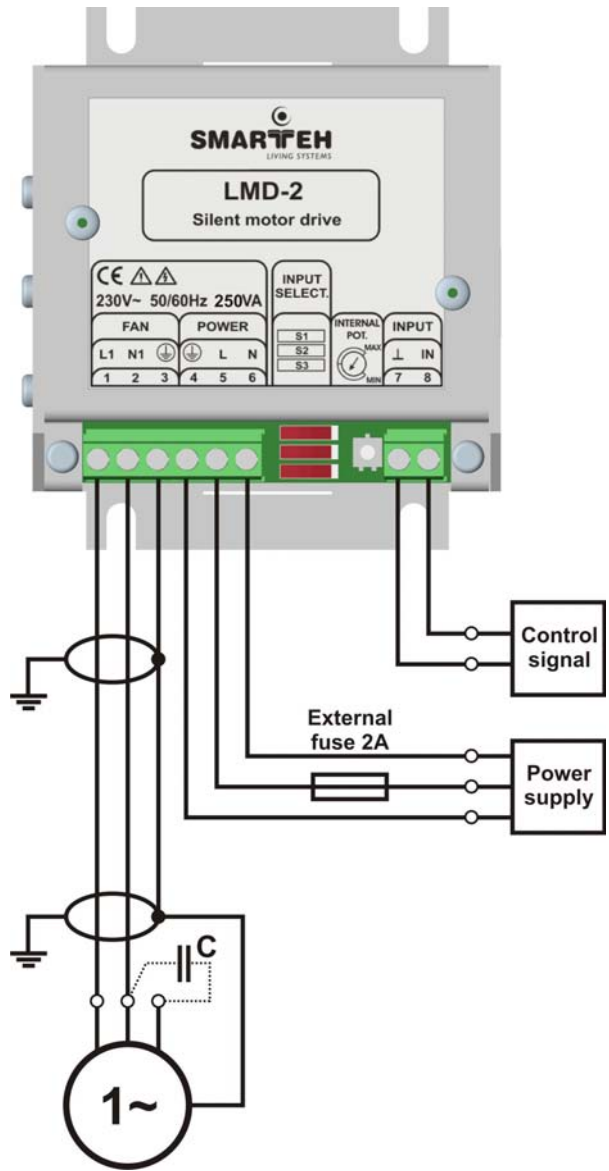

Note: For wiring motor with capacitor shifted winding always connect FAN.1 (L1) from LMD-2 to motor winding with no capacitor connected, as shown on Figure 2



Table 2: FAN





FAN.1	230 VAC	Phase line
FAN.2	230 VAC	Neutral line
FAN.3	PE	Protective earth

Table 3: POWER

POWER.4	PE	Protective earth
POWER.5	230 VAC	Power supply - Phase line
POWER.6	230 VAC	Power supply - Neutral line

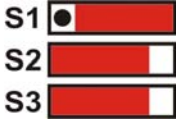
Control signal is different for various versions of JUMPER settings. When internal potentiometer is selected, use installed potentiometer for fan speed setting. See Table 4 below.

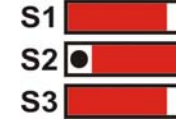
Table 4: INPUT

					Input selection switches
INPUT.7	⊥	⊥	⊥	⊥	Control signal reference
INPUT.8	0 .. 10 V	0 .. 20 mA	External 10kΩ potentiometer	* Internal potentiometer	Control signal input

* Additional switch can be added between control signal reference (INPUT.7) and control signal input (INPUT.8) for switching LMD-2 silent motor drive on / off:

- when switch is off, contact break, LMD-2 is on and output voltage is related to internal potentiometer position
- when switch is on, contact made, LMD-2 output is off



3.2 Mounting instructions

Figure 3: Housing dimensions

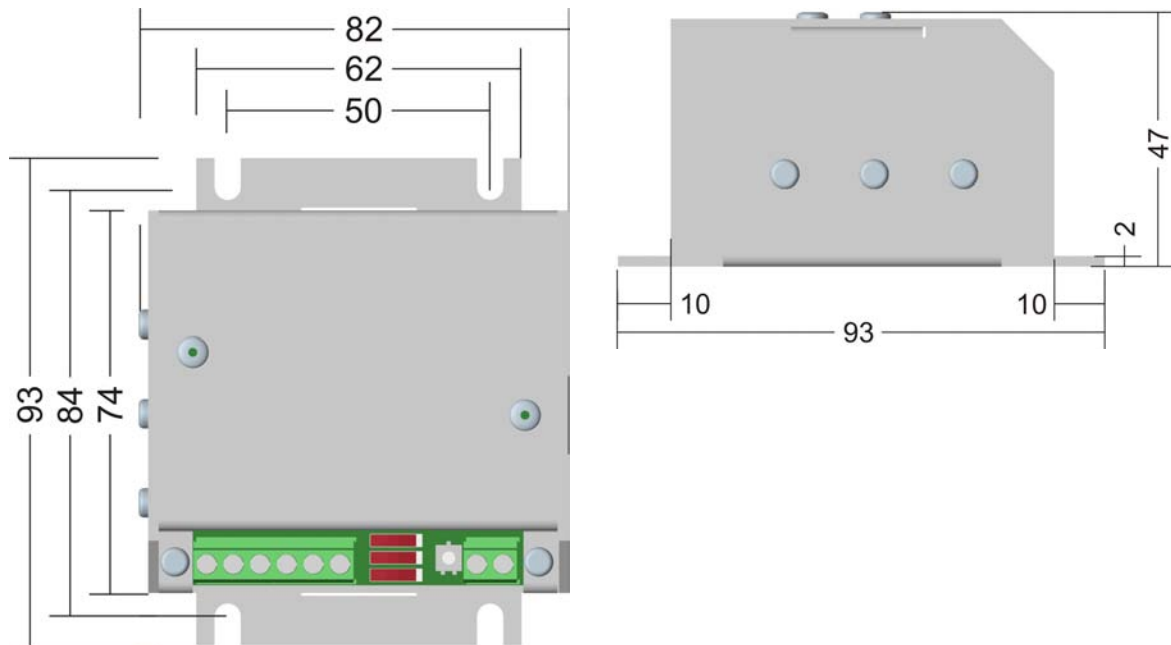

- Dimensions in millimeters.

EXTERNAL SWITCH OR CIRCUIT-BREAKER AND EXTERNAL OVERCURRENT PROTECTION: The unit is allowed to be connected to installation with over current protection that has nominal value of 2 A up to 10 A.

RECOMMENDATION ON SWITCH OR CIRCUIT-BREAKER PROTECTION: There should be two poles main switch in the installation in order to switch off the unit. The switch should meet the requirements of standard IEC60947 and have a nominal value at least 10 A. The switch or circuit-breaker should be within easy reach of the operator. It should be marked as the disconnecting device for the equipment.



All connections, module attachments and assembling must be done while module is not connected to the main power supply.



Mounting instructions:

1. Switch OFF main power supply.
2. Mount LMD-2 to the provided place.
3. Connect drive output wires according to the connection scheme in Figure 2.
4. **ATTENTION: Check again that the connected load power does not exceed 250 VA!**
5. Connect power supply wires according to the connection scheme in Figure 2.
6. Switch ON main power supply.

Dismount in reverse order.

For good heat transfer from the unit it should be mounted on metal surface or adequate air cooling should be provided.

The unit must be connected to protective earthing of the mains supply installation.

Unit wiring must be accomplished with wires with temperature range 105°C.



3.3 Module labeling

Below is example prototype only.

Figure 5: Labels on housing

Label 1 example:

LMD-2.U01
 P/N:208LMD10001002
 D/C: 34/10

Label 2 example:

S/N: LMD-S9-1000000190

Label 1 description:

1. **LMD-2** is the full product name.
U01 - version
2. **P/N:208LMD10001002** is the part number.
 - **208** - general code for product family,
 - **LMD** - short product name,
 - **10001** - sequence code,
 - 10 - year of code opening
 - 001 - derivation code
 - **002** - version code (reserved for future HW and/or SW firmware upgrades).
3. **D/C:34/10** is the date code.
 - **16** - week and
 - **10** - year of production.

Label 2 description:

1. **S/N:LMD-S9-0500000190** is the serial number.
 - **LMD** - short product name,
 - **S9** - user code (test procedure, e.g. Smarteh person xxx),
 - **1000000190** - year and current stack code,
 - 10 - year (last two cyphers)
 - 00000190 - current stack number; previous module would have the stack number 00000189 and the next one 00000191.



4 TECHNICAL SPECIFICATIONS

Table 6: Technical specifications

Power supply	230 V AC, -15% +10%, 50/60 Hz
Maximum load	250 VA
Rated load voltage	230 VAC, 50/60 Hz
Rated load current	1.1 A
Output switching frequency	> 20 kHz
Connection type	screw type connectors for stranded wire 0.75 to 2.5 mm ²
Dimensions (L x W x H)	82 x 93 x 47 mm
Weight	350 g
Ambient temperature	0 to 40 °C
Ambient humidity	max. 95 %, no condensation
Transport and storage temperature	-20 to 60 °C
Pollution degree	2
Overvoltage category	II





5 CHANGES

The following table describes all the changes to the document.

Date	V.	Description
2.9.2010	001	The initial version, issued as LMD-2 <i>UserManual</i> .





6 NOTES

